

# Lens compensators

by Belman Production A/S



## Belman designs and supplies lens compensators.

### Properties

Lens compensators are often a customer requirement as the customer could require a single layer bellow. If the thickness of material of the single layer bellow is more than 4 mm it is not possible to supply a normally manufactured bellow. In this case a lens compensator is the solution. Normally the difficulty with the material thickness is solved by supplying a multi layer bellow, but in some cases this is not accepted by the customer.

### Construction

Lens compensators are constructed as illustrated on the drawings beside. In that way lens compensators are supplied as a half convolution, a convolution or as a bellow. According to the customers requirements these are either supplied welded together or they are welded together on site.

Lens compensators are furthermore constructed in both stainless steel and carbon steel and in the dimension area 4-8 mm.

Other dimensions and/or material thicknesses on request.

Furthermore the construction is as follows:

- Radius: 20, 30, 50, 60 and 80 mm.
- Height of convolution: Min.  $2 \times (\text{radius} + \text{thickness})$ , but max. 300 mm.
- Inner diameter: Min. 400 mm.
- Outside diameter: Max. 5000 mm. Larger dimensions are supplied in segments.
- Design according to: EJMA, EN 13445-3, ASME or AD2000.

### Advantages

- Higher thicknesses of materials are possible.
- Higher convolutions are often possible.
- The customer requirements of a single layer bellow are met even though the thickness of material is higher.

### Application

Among others in all industries that use pressurized equipment, heat exchangers etc. where higher pressure and higher temperature require higher thickness of material.

**Lens compensators  
- a possibility for single layer bellows  
with higher thickness of material!**

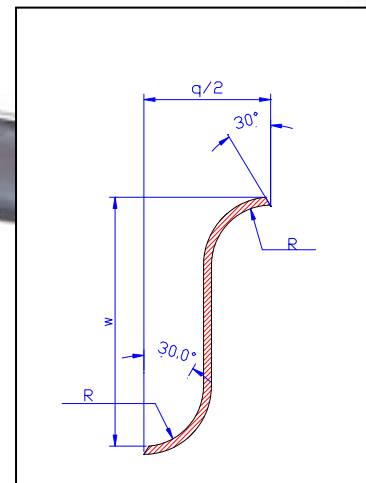

Half convolution

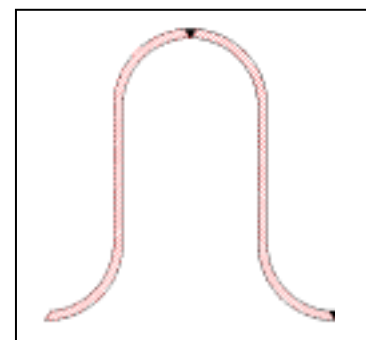

Convolution from two half convolutions welded together. The black triangle illustrates the welding.

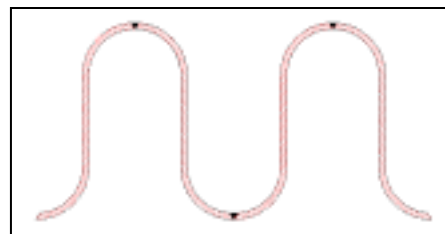

Bellow from two convolutions welded together or four half convolutions. The black triangles illustrate the weldings.

Belman